

Baureihe ZU 250

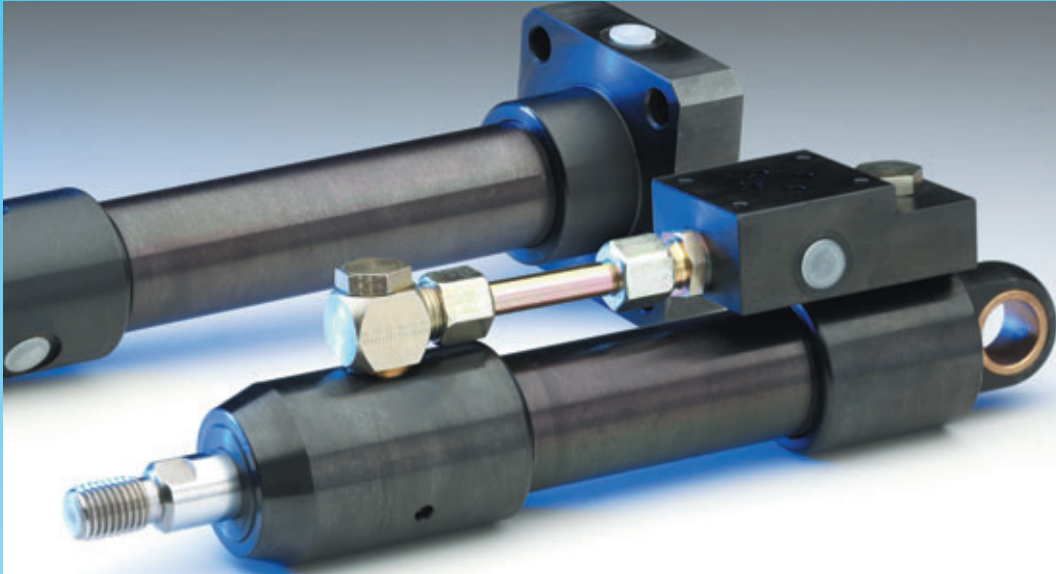

250 bar Hydraulikzylinder

Kolben Ø 20-100 mm

Hublängen nach Wahl (Knickfestigkeit beachten, siehe Seite 35)

- Runde, kompakte Bauform; schwarz brüniert
- Kolbenstange hartverchromt; mit Staubabstreifer
- Besonders geeignet für den Einbau in Maschinen und Vorrichtungen

Bestimmen Sie Ihren 250 bar Hydraulikzylinder:

Bestellbeispiel: **ZU250-G 25/140 Dbb-H03 E1 1g G1/4" As4**

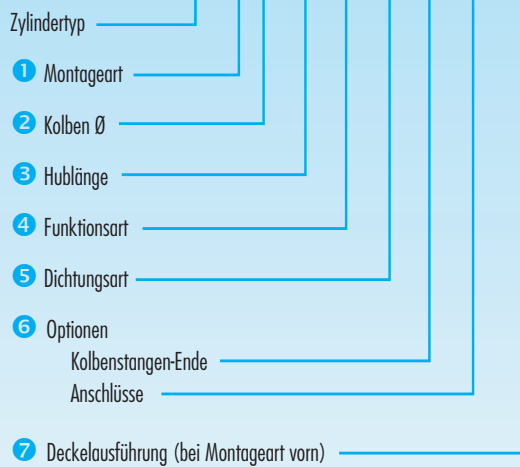

Sonderausführungen auf Anfrage

1 Montagearten

A Grundausführung



H Fußbefestigung

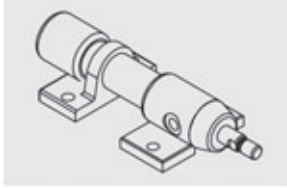

G Gewindebefestigung



Gz Gewinde mit Zentrierung



Fv Flansch vorn

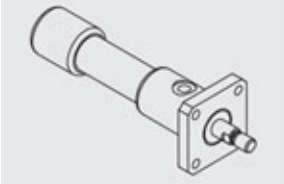

Fh Flansch hinten

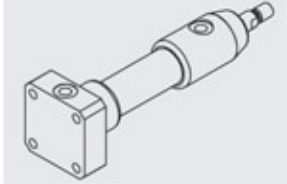

Si Schwenklagerung

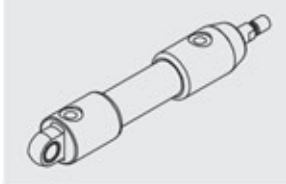

Sk Gelenklagerung



Sonder-Montagearten: (auf Anfrage)

Sv Lagerbolzen vorn

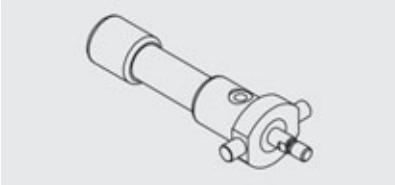

Sm Lagerbolzen mittig

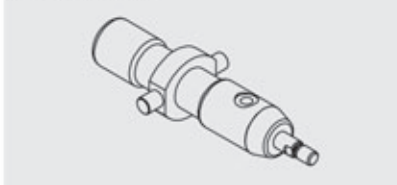

S Lagerbolzen hinten

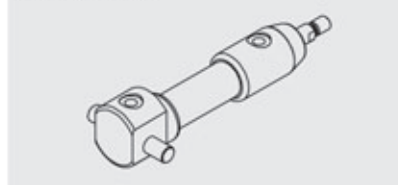

2 Kolben Ø

Kolben Ø (mm)	20	25	32	40	50	55	63	70	80	90	100
Kolbenfläche stoßend (cm ²)	3.14	4.90	8.05	12.5	19.6	23.7	31.1	38.5	50.2	63.6	78.5
Kolbenfläche ziehend (cm ²)	2.0	2.9	4.9	7.6	11.6	15.6	18.6	25.9	30.6	44.0	50.2

3 Hublänge

Hublängen nach Wahl: Wir fertigen für Sie jede gewünschte Hublänge.

4 Funktionsarten

D Doppelwirkend



E Einfachwirkend



Ez Einfachwirkend



Dbb Doppelwirkend



Sonder-Funktionsarten: (auf Anfrage)

Dd Doppelwirkend



Dbv Doppelwirkend



Dbh Doppelwirkend



F Einfachwirkend



Fz Einfachwirkend



5 Dichtungsarten

Standardausführung: H00 für Hydrauliköl (Mineralöl). Dichtungsarten für andere Druckmedien auf Anfrage.

Dichtungsarten	H00	H03	H06	H11
Kolbendichtung Nutring	●			
Kolbendichtung PTFE-Gleitring		●	●	●
Stangendichtung Nutring	●	●		
Stangendichtung PTFE-Gleitring			●	●
Staubabstreifer	●	●	●	●
O-Ringe Nitril	●	●	●	
O-Ringe Viton				●
Kolbengeschwindigkeit				
max. 0,5 m/s	●	●		
max. 10 m/s			●	●
Temperaturbereich				
-20/+100 °C	●	●	●	
-20/+200 °C				●

6 Optionen

Kolbenstangen-Ende:

Standardausführung: E11

Weitere Ausführungen wie abgebildet, werden bei fehlenden Angaben des Kunden nach Katalog ausgeführt.

Ausführungen nach Kundenwunsch sind auf Anfrage möglich.

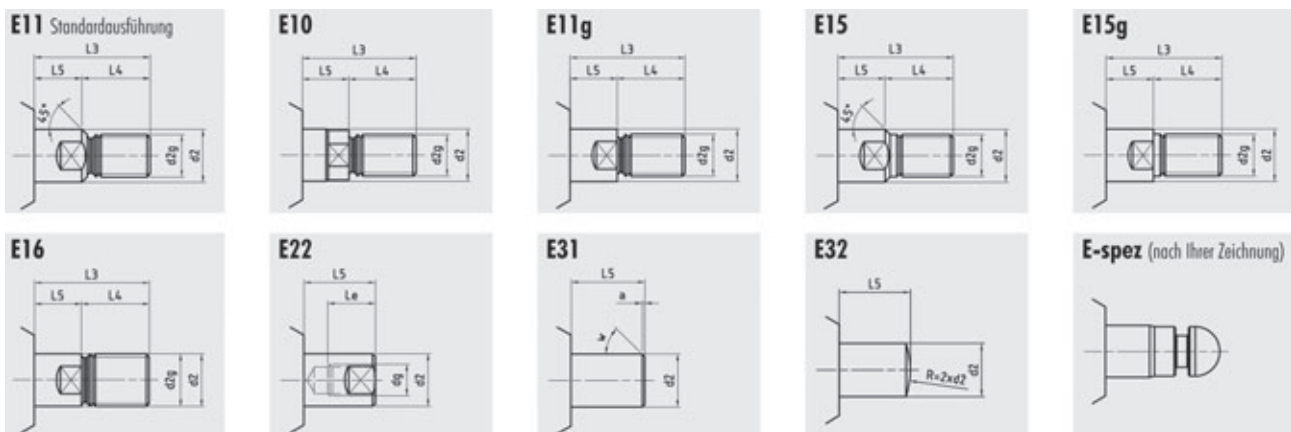

Anschlüsse:

Werden bei fehlen Angaben des Kunden nach Katalog ausgeführt.

Die Stellung der Anschlüsse kann auf Wunsch des Kunden verändert werden.

Größere und andere (metrische) Anschlüsse sind auf Anfrage möglich.

Entlüftungsschrauben (ES):

Werden auf Bestellung und nach Lage-Angabe des Kunden angebracht.

7 Deckelausführung (bei Zylinderkopfseitiger Montage/Befestigung)

As1 Deckel mit Anschluss axial (Längenmaß L1v) Standardausführung

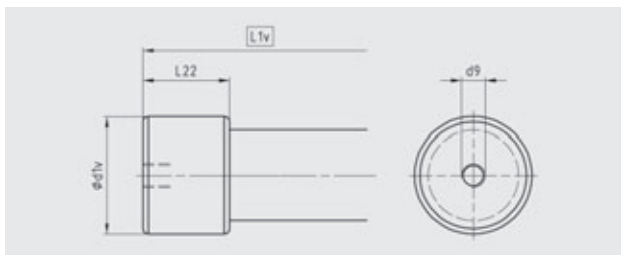

As4 Deckel mit Anschluss seitlich (Längenmaß L1h)

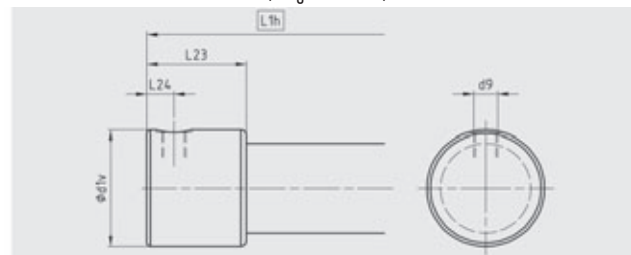

Kolben Ø	20	25	32	40	50	55	63	70	80	90	100
L22	39	41	44	48	56	57	59	61	64	62	78
L23	45	45	53	55	67	67	68	68	72	70	82
L24	12	12	15	15	19	19	19	19	20	20	22

Maßbilder/Baum Maße

A Grundausführung

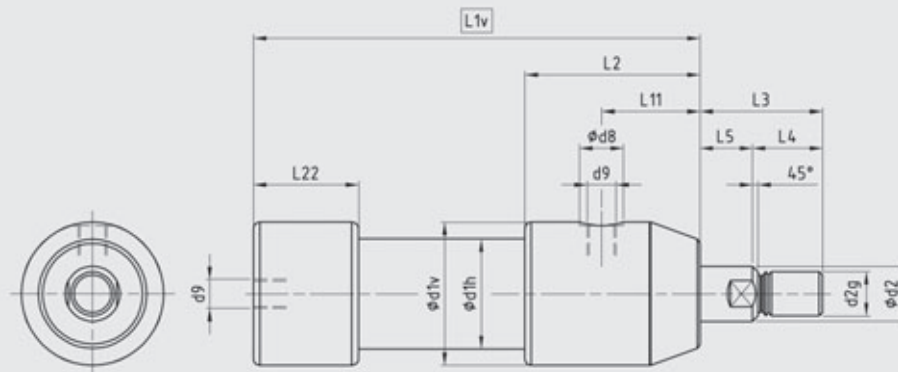

H/H2 H: Fuß vorn/H2: zwei Füße

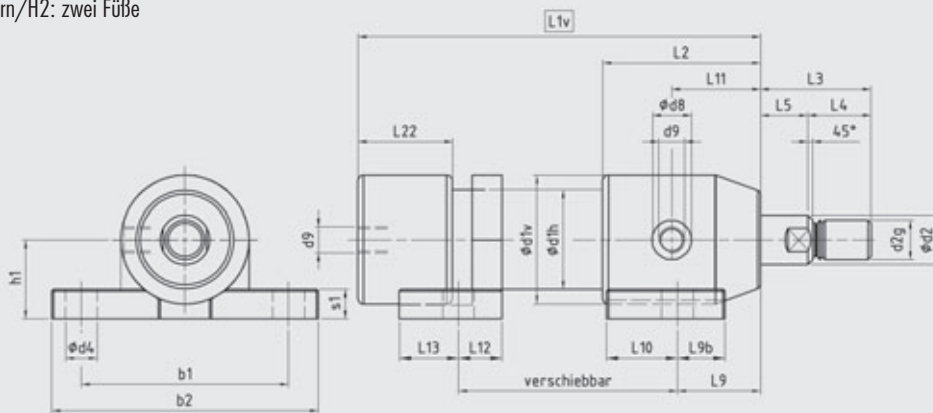

Kolben Ø	20	25	32	40	50	55	63	70	80	90	100
d1v	35	42	52	65	80	90	100	110	125	135	150
d1h	26	33	40	50	65	70	80	90	100	112	124
d2-f7	12	16	20	25	32	32	40	40	50	50	60
d2g	M10	M12	M16	M20	M24	M24	M33	M33	M42	M42	M48
d4	9	11	13	16	17	17	22	22	26	26	29
d8	16	16	20	20	26	26	26	26	33	33	33
d9	G 1/8"	G 1/8"	G 1/4"	G 1/4"	G 3/8"	G 3/8"	G 3/8"	G 3/8"	G 1/2"	G 1/2"	G 1/2"
b1	60	70	85	105	130	140	155	170	190	210	230
b2	76	90	110	135	162	176	195	210	240	260	280
h1±0,1	22	25	32	40	50	56	63	70	80	90	100
s1	8,5	10	14	15	17	18	20	22	23	24	26
L2	61	61	72	80	95	100	107	115	125	132	145
L3	32	40	47	56	63	63	77	77	91	91	100
L4	16	22	26	32	35	35	45	45	55	55	60
L5	16	18	21	24	28	28	32	32	36	36	40
L9	36	33	39	42	50	54	59	63	69	72	80
L9b	17	20	20	24	25	28	30	32	34	37	40
L10	23	26	30	36	40	42	44	48	51	55	60
L11	31	31	39	45	53	58	65	72	79	85	90
L12	15	18	20	22	26	28	30	32	34	37	40
L13	20	24	27	30	35	38	40	43	45	50	54
L22	39	41	44	48	56	57	59	61	64	62	78
L23	45	45	53	55	67	67	68	68	72	70	82
L24	12	12	15	15	19	19	19	19	20	20	22

Funktionsart

Längenmaß L1v (mit Standard-Deckelaußführung As1) und Längenmaß L1h (mit Deckelaußführung As4)

D/E/Ez	L1v = Hub +	91	96	112	124	141	150	161	174	185	197	209
	L1h = Hub +	97	100	121	131	152	160	170	181	193	205	213
Dbb	L1v = Hub +	103	110	128	142	161	170	183	196	209	221	237
	L1h = Hub +	109	114	137	149	172	180	192	203	217	229	241

Mindest-Längenmaß L1v und L1h

L1v =	101	103	117	129	152	158	167	177	190	195	224
L1h =	107	107	126	136	163	168	176	184	198	203	228

Maßbilder/Baumaße

G Gewindebefestigung

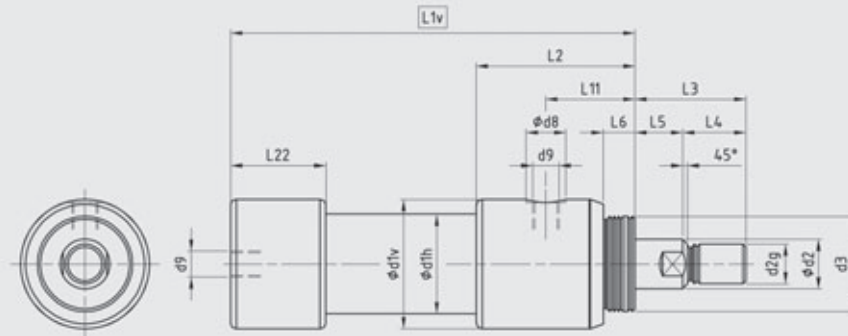

Gz Gewindebefestigung mit Zentrierung

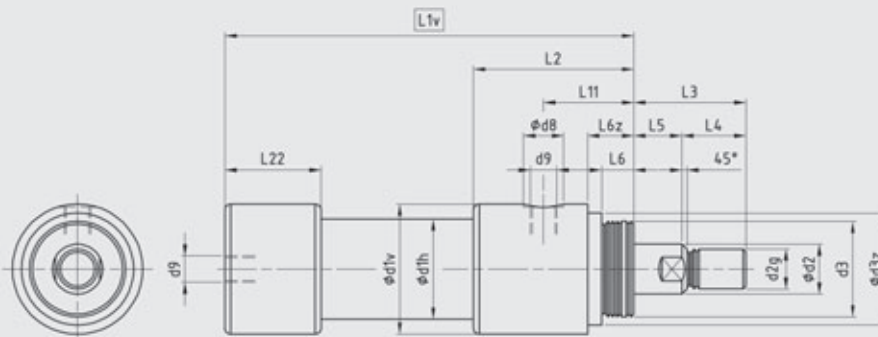

Kolben Ø	20	25	32	40	50	55	63	70	80	90	100
d1v	35	42	52	65	80	90	100	110	125	135	150
d1h	26	33	40	50	65	70	80	90	100	112	124
d2-f7	12	16	20	25	32	32	40	40	50	50	60
d2g	M10	M12	M16	M20	M24	M24	M33	M33	M42	M42	M48
d3	G 3/4"	G 1"	G 1 1/4"	G 1 1/2"	G 2"	G 2"	G 2 1/2"	G 2 1/2"	G 3"	G 3"	G 4"
d3z-h7	28	38	46	56	70	75	90	90	110	110	125
d8	16	16	20	20	26	26	26	26	33	33	33
d9	G 1/8"	G 1/8"	G 1/4"	G 1/4"	G 3/8"	G 3/8"	G 3/8"	G 3/8"	G 1/2"	G 1/2"	G 1/2"
L2	61	61	72	80	95	100	107	115	125	132	145
L3	32	40	47	56	63	63	77	77	91	91	100
L4	16	22	26	32	35	35	45	45	55	55	60
L5	16	18	21	24	28	28	32	32	36	36	40
L6	9	11	14	16	20	20	25	25	35	35	40
L6z	13,5	16	21	23	30	30	35	35	49	49	54
L11	31	31	39	45	53	58	65	72	79	85	90
L22	39	41	44	48	56	57	59	61	64	62	78
L23	45	45	53	55	67	67	68	68	72	70	82
L24	12	12	15	15	19	19	19	19	20	20	22

Funktionsart		Längenmaße L1v (mit Standard-Deckelausführung As1) und Längenmaße L1h (mit Deckelausführung As4)										
D/E/Ez	L1v = Hub +	91	96	112	124	141	150	161	174	185	197	209
	L1h = Hub +	97	100	121	131	152	160	170	181	193	205	213
Dbb	L1v = Hub +	103	110	128	142	161	170	183	196	209	221	237
	L1h = Hub +	109	114	137	149	172	180	192	203	217	229	241
		Mindest-Längenmaße L1v und L1h										
	L1v =	101	103	117	129	152	158	167	177	190	195	224
	L1h =	107	107	126	136	163	168	176	184	198	203	228

Maßbilder/Baumaße

Fv Flansch vorn

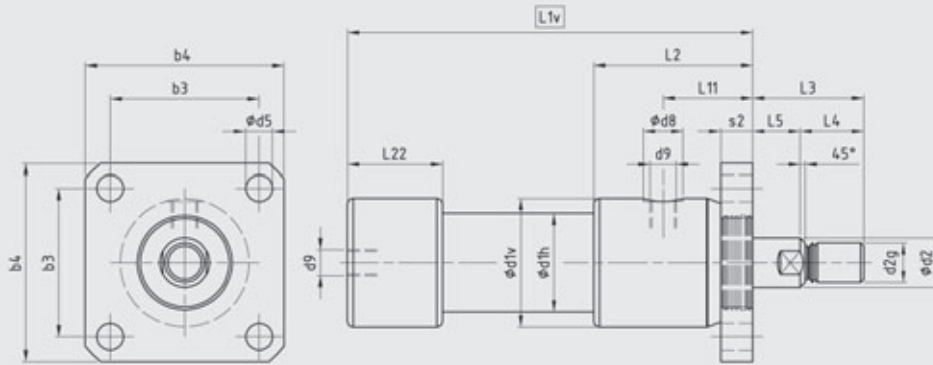

Fh Flansch hinten

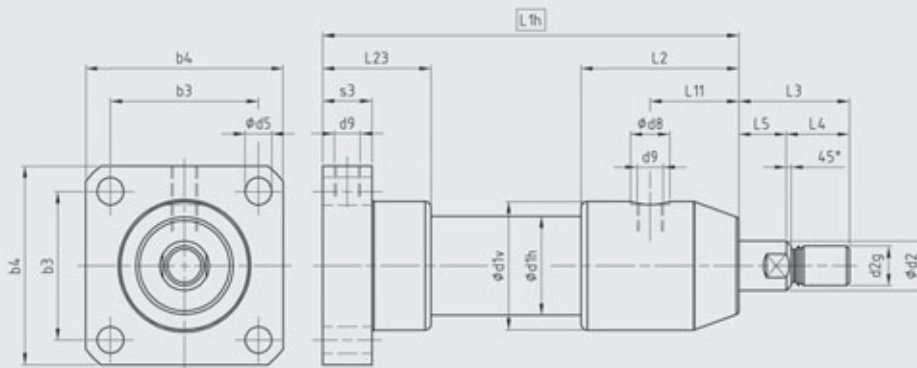

Kolben Ø	20	25	32	40	50	55	63	70	80	90	100
d1v	35	42	52	65	80	90	100	110	125	135	150
d1h	26	33	40	50	65	70	80	90	100	112	124
d2-f7	12	16	20	25	32	32	40	40	50	50	60
d2g	M10	M12	M16	M20	M24	M24	M33	M33	M42	M42	M48
d5	7	9	11	13,5	13,5	13,5	17,5	17,5	17,5	17,5	20
d8	16	16	20	20	26	26	26	26	33	33	33
d9	G 1/8"	G 1/8"	G 1/4"	G 1/4"	G 3/8"	G 3/8"	G 3/8"	G 3/8"	G 1/2"	G 1/2"	G 1/2"
b3	40	48	62	75	85	95	105	110	125	130	150
b4	55	70	85	100	115	125	140	145	160	165	190
s2	9	11	14	16	20	20	25	25	35	35	40
s3	20	20	25	25	30	30	30	30	30	30	30
L2	61	61	72	80	95	100	107	115	125	132	145
L3	32	40	47	56	63	63	77	77	91	91	100
L4	16	22	26	32	35	35	45	45	55	55	60
L5	16	18	21	24	28	28	32	32	36	36	40
L11	31	31	39	45	53	58	65	72	79	85	90
L22	39	41	44	48	56	57	59	61	64	62	78
L23	45	45	53	55	67	67	68	68	72	70	82
L24	12	12	15	15	19	19	19	19	20	20	22

Funktionsart		Längenmaße L1v und Längenmaße L1h (mit Deckelausführung As4)										
D/E/Ez	L1v = Hub +	91	96	112	124	141	150	161	174	185	197	209
	L1h = Hub +	97	100	121	131	152	160	170	181	193	205	213
Dbb	L1v = Hub +	103	110	128	142	161	170	183	196	209	221	237
	L1h = Hub +	109	114	137	149	172	180	192	203	217	229	241
		Mindest-Längenmaße L1v und L1h										
	L1v =	101	103	117	129	152	158	167	177	190	195	224
	L1h =	107	107	126	136	163	168	176	184	198	203	228

Maßbilder/Baumaße

Si Schwenklagerung mit Bronzebüchse

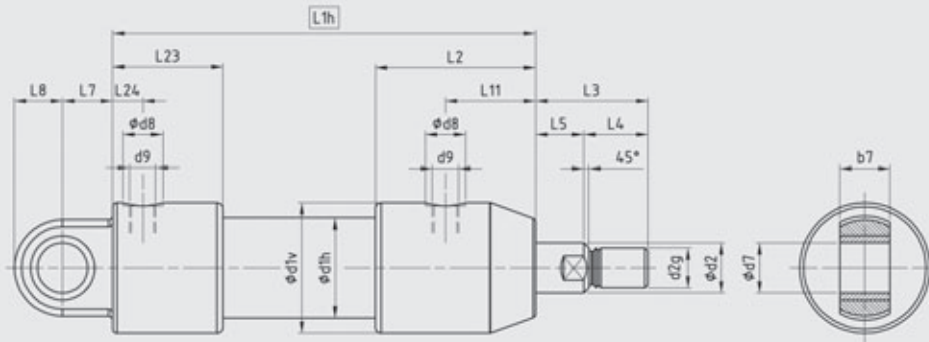

Sk Gelenklagerung mit Stahl/Stahl-Gelenklager

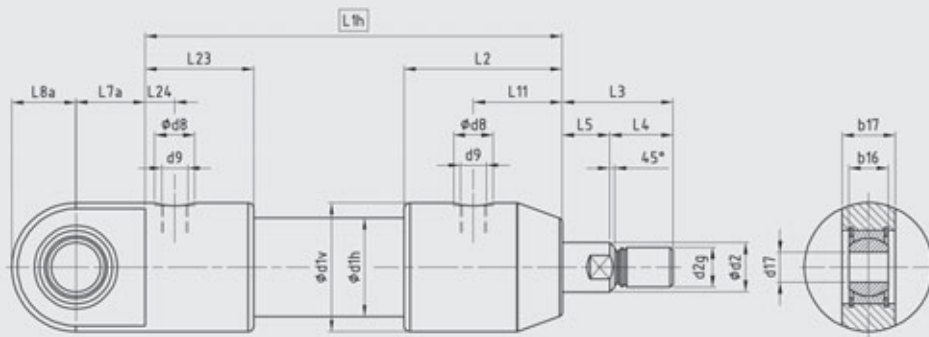

Kolben Ø	20	25	32	40	50	55	63	70	80	90	100	
d1v	35	42	52	65	80	90	100	110	125	135	150	
d1h	26	33	40	50	65	70	80	90	100	112	124	
d2-f7	12	16	20	25	32	32	40	40	50	50	60	
d2g	M10	M12	M16	M20	M24	M24	M33	M33	M42	M42	M48	
d7-H7	12	16	20	25	32	32	40	40	50	50	60	
d8	16	16	20	20	26	26	26	26	33	33	33	
d9	G 1/8"	G 1/8"	G 1/4"	G 1/4"	G 3/8"	G 3/8"	G 3/8"	G 3/8"	G 1/2"	G 1/2"	G 1/2"	
d17-H7	12	15	20	25	30	30	40	40	50	50	60	
b7	12	16	20	25	32	32	40	40	50	50	60	
b16	10	12	16	20	22	22	28	28	35	35	44	
b17	13	15	21	27	29	29	34	34	41	41	52	
L2	61	61	72	80	95	100	107	115	125	132	145	
L3	32	40	47	56	63	63	77	77	91	91	100	
L4	16	22	26	32	35	35	45	45	55	55	60	
L5	16	18	21	24	28	28	32	32	36	36	40	
L7	12	16	20	25	32	32	40	40	50	50	60	
L7a	20	25	28	35	42	42	52	52	65	65	78	
L8	11,5	15	19	24	31	31	38	38	48	48	58	
L8a	17,5	21	26	32,5	40	40	50	50	62,5	62,5	75	
L11	31	31	39	45	53	58	65	72	79	85	90	
L23	45	45	53	55	67	67	68	68	72	70	82	
L24	12	12	15	15	19	19	19	19	20	20	22	
Funktionsart	Längenmaße L1h											
D/E/Ez	L1h = Hub +	97	100	121	131	152	160	170	181	193	205	213
Dbb	L1h = Hub +	109	114	137	149	172	180	192	203	217	229	241
	Mindest-Längenmaße L1h											
L1h =	107	107	126	136	163	168	176	184	198	203	228	